

AUTOMATIC COVER CARTON SEALER

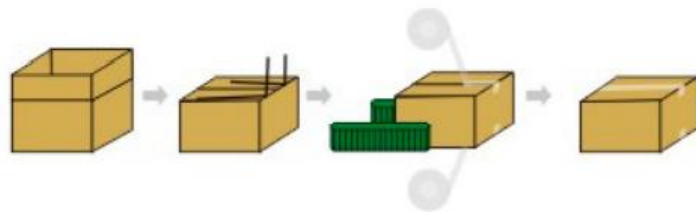

Automatic cover carton sealer suitable for the use of various specifications of carton at the same time, automatic size adjustment when changing specifications, using belt drive, can pack 900 cases/hour

Space required for machine installation

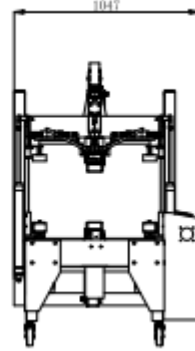
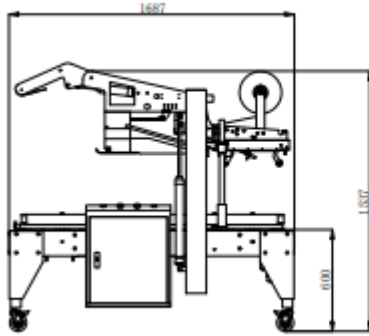

Sealing speed: 800 ~ 900 cases/hour

Sealing size:

Length (L) : L200 ~ 600mm

Width (W) : W150 ~ 500mm

Height (H) : H120 ~ 500mm

Applicable tape: 48 ~ 60 ~ 75Wmm×1000ML

Mechanical size: L1687*W1047*H1537mm

Noise level: Max 80dBA

Use power supply (optional) :

220V/50Hz/60Hz/1Ph

380V/50Hz/60Hz/3Ph

Table height: 570 ~ 770mm

Machine weight: ≈248KG

Power consumption: Maximum 0.2KW

Use air source: 6kgf/cm² 100nl/min

INSTALLATION

The power supply system, voltage and frequency must correspond to the regulation label attached to the machine.

Connect the plug.

Operate the machine by the side switch.

NOTICE:

Please install the machine where a power supply can be easily connected.

It is necessary to disconnect the power supply plug prior to open the control box's cover.

ADJUSTMENT

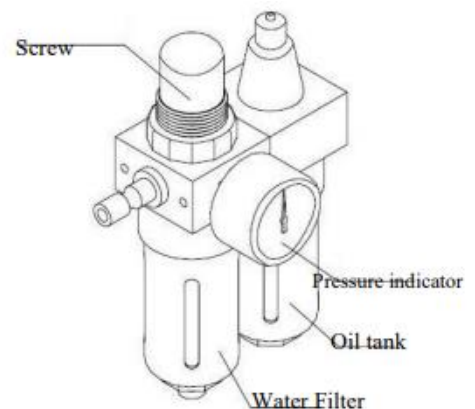
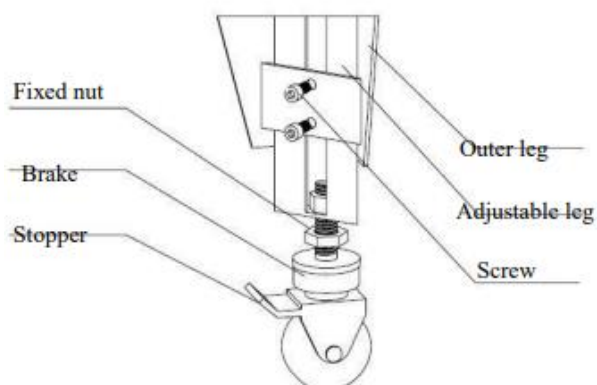

Note:

Do not switch on the power supply before installation and adjustment.

Step 1 (Adjust the height of the workbench)

Place the equipment in the corresponding working area, as required

Adjust the height of the working surface.

Specific operation: loosen the "adjusting bolt" and adjust the "extension"

Shrink feet ", reach the required height of the operation, lock "adjustment

Bolt "and press down the" stop "to make the machine fixed.

Step 2 (Adjust the main air source)

Connect the air source, lift the adjusting knob and turn it clockwise

Increase the pressure, turn counterclockwise to reduce the pressure, and observe the pressure gauge

The value is 5-6kg/ cm². After adjustment, lock the screw

Button

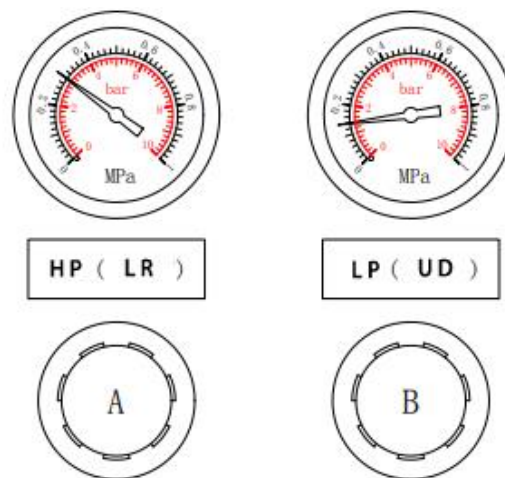

Step 3 (High and low pressure adjustment)

Pressure adjustment depends on carton quality

a, knob A is to adjust the pressure of the side clamp belt (about 2.5-3kg/cm²). The carton conveying does not move, pull the unlock knob. Turn knob A

Rotate clockwise to increase the pressure; If there is A welt after the carton is clamped, turn the knob A counterclockwise to reduce the pressure. After adjustment,

Lock the knob.

B. Knob b is to adjust the pressure maintained by the upper cutter (about 1.2-1.5kg/cm²).

If the carton is not pressed tightly, pull the unlock knob. Turn knob B

Counterclockwise rotation to reduce pressure; If the carton is damaged after pressing,

turn knob B clockwise to increase the pressure. After adjustment, Lock the knob.

Note: When adjusting the high and low pressure, please first determine whether the pressure of the main air source is 5-6 kg/cm².

Thread illustration

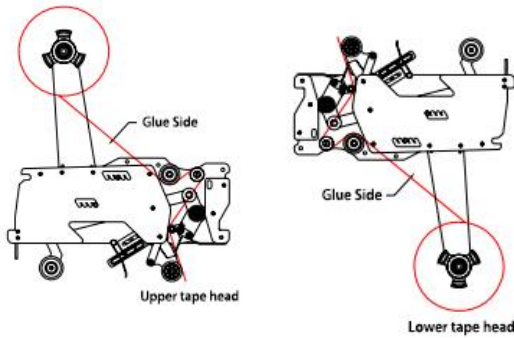

MAINTENANCE AND LUBRICATION

Please read the instruction manual prior to perform maintenance and inspection works.

Before performing maintenance work, please shut down the machine and disconnect the power supply, it is an important step to avoid missend the electricity.

If it is necessary to use the different specification of tape, please refer to the part list in this manual.

Periodically clean the grime, dust and dirt stuck on the belt and clean up any other parts of the machine.

To extend the blade longevity, please check if there are too much surplus viscose stuck on the blade, please clean it up and lubricate it.

To maintain the normal operation of the machine, please lubricate the movable parts of the machine weekly.