

## SEMI-AUTOMATIC WRAPPING MACHINE WITH RAMP

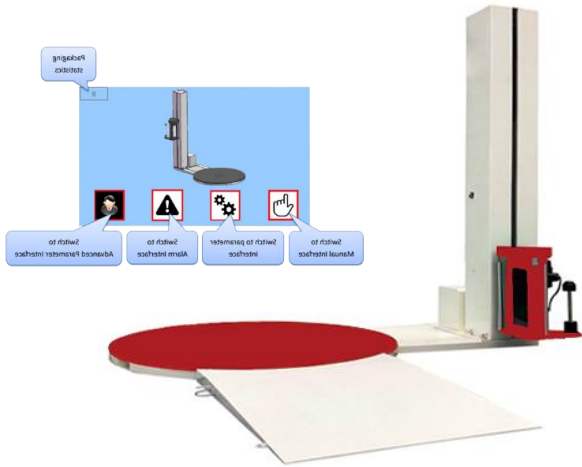

CARRIAGE DESIGN WITH CE SAFETY CERTIFICATION,  
RAMP MAKES LOADING AND UNLOADING EASIER AND FASTER

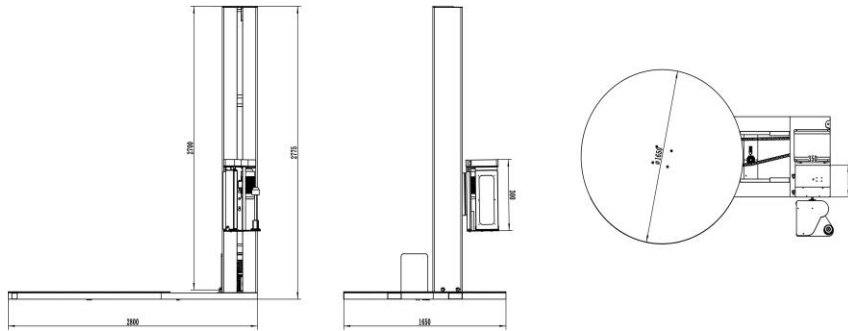

LAYOUT SIZE DRAWING (MM)

PLC AND TOUCH SCREEN CONTROL, WINDING PARAMETERS CAN BE SET  
PHOTOELECTRIC SWITCH, SELF-DYNAMIC MEASUREMENT OF CARGO HEIGHT  
WITH SWITCH PROTECTION DEVICE AND EMERGENCY STOP SWITCH DEVICE  
REMOTE CONTROL SWITCH FOR REMOTE CONTROL, CONVENIENT OPERATION  
REINFORCE THE WINDING FUNCTION TO PROVIDE SPECIAL PROTECTION FOR CERTAIN PARTS

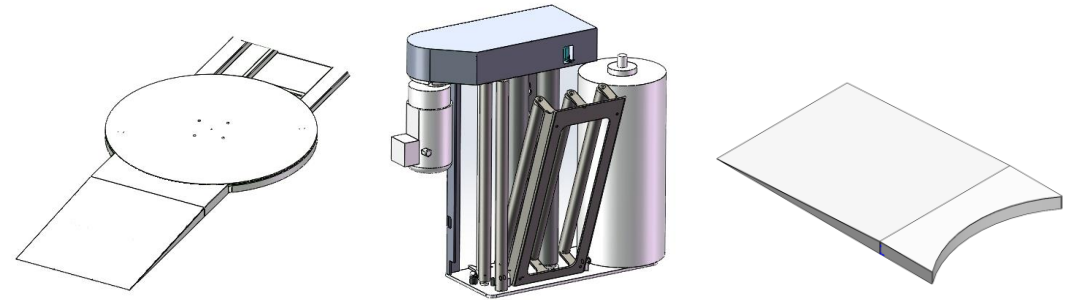

CARRIAGE DESIGN WITH CE SAFETY CERTIFICATION, RAMP MAKES LOADING AND UNLOADING EASIER

Item	Unit	Parameter
Pallet diameter	mm	1500/1650/1800/2000/2200/2400
Max load weight	Kg	1500/2000/2500/3000
Plate rotation speed	Rpm	5~15
Carriage speed up-down	m/min	1.5~5.5
Carriage type		Mechanical/DC/AC
Film tensioning		Adjustable by touch screen
Film pre-stretch	%	125~400
Maximum pallet dimensions L*W	mm	1000~1400*1000~1400
Maximum product height	mm	2400/2700/3000
Power supply	V	220V/1P±10%/50 or 60Hz
Installed power	Kw	1.5/2.2/2.5/3.0
Reel film size	mm	500*260
Weight of film reel	Kg	15/20/25
Film thickness	um	17~35
Forklifting		Electric forklift truck/ Optional slope