

SIX-SIDED PACKING AND CONVEYING SYSTEM

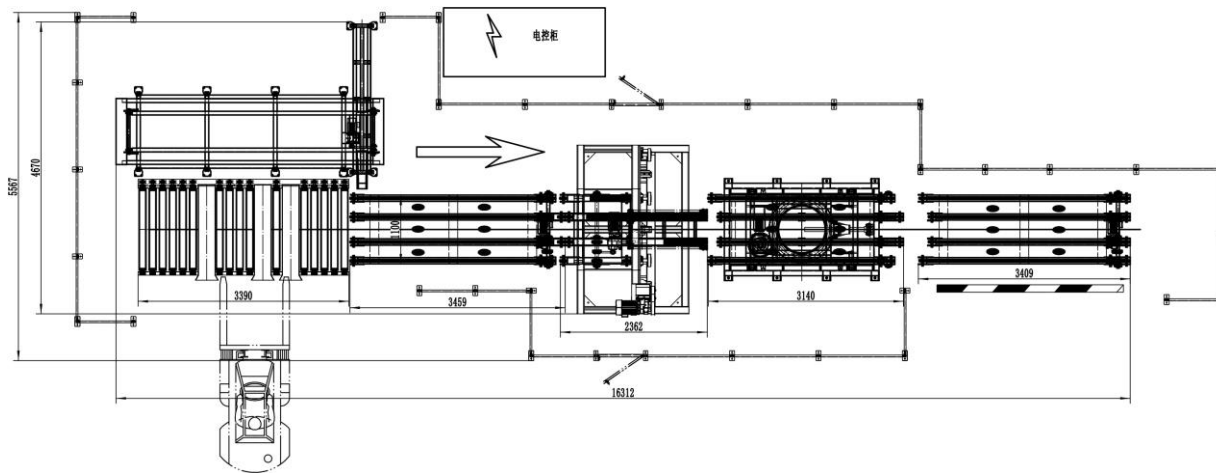

AXIAL AND CIRCUMFERENTIAL WRAP
ALL PACKING PROCESSES CAN BE COMPLETED AUTOMATICALLY
THE PACKAGED GOODS ARE MOISTURE-PROOF, DUST-PROOF, TIGHTLY BOUND AND FAST TRANSSHIPMENT.



LAYOUT SIZE DRAWING (MM)

AXIAL AND CIRCUMFERENTIAL WRAP
 ALL PACKING PROCESSES CAN BE COMPLETED AUTOMATICALLY
 PLC AND TOUCH SCREEN CONTROL, WINDING PARAMETERS CAN BE SET WITH SWITCH PROTECTION DEVICE AND EMERGENCY STOP SWITCH DEVICE
 REMOTE CONTROL SWITCH FOR REMOTE CONTROL, CONVENIENT OPERATION
 PHOTOELECTRIC SWITCH, SELF-DYNAMIC MEASUREMENT OF CARGO INFORMATION
 REINFORCE THE WINDING FUNCTION TO PROVIDE SPECIAL PROTECTION FOR CERTAIN PARTS
 THE PACKAGED GOODS ARE MOISTURE-PROOF, DUST-PROOF, TIGHTLY BOUND AND FAST TRANSSHIPMENT.

Item	Unit	Parameter
Goods size	mm	L2400*W1200*H950/ Customizable
Max load weight	Kg	2000/2500/3000/3500/4000/ Customizable
Ring rotation speed	Rpm	35rpm/ frequency control
Film breaking device		Pneumatic/electric control, electric heating wire/cutter film;
Carriage type		Mechanical/DC/AC
Film tensioning		Adjustable by touch screen
Film pre-stretch	%	150-250
Regulator		Damping adjustment, stepless speed regulation
Ring diameter	mm	2000/2200/ Customizable
Power supply	V	380V/3P±10% PE/50 or 60Hz
Installed power	Kw	30/ Customizable
Reel film size	mm	500*260
Weight of film reel	Kg	15/20/25
Film thickness	um	17~35
Mode of driving		Roller/chain/belt/chain plate

