

AUTOMATIC TOP SHEET WRAPPING MACHINE

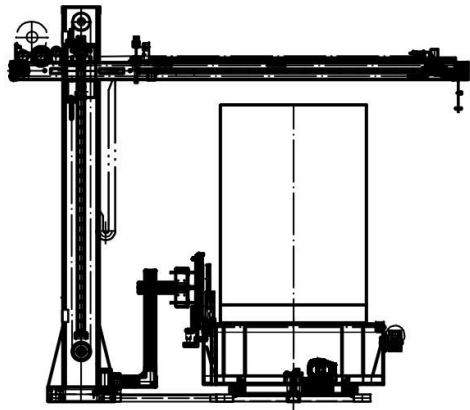

AUTOMATIC FILM SEND, AUTOMATIC WELDING FILM, HIGH EFFICIENCY AND SAFETY  
OPTIONAL AUTOMATIC FILM FEEDING, AUTOMATIC WELDING FILM, HIGH EFFICIENCY AND SAFETY

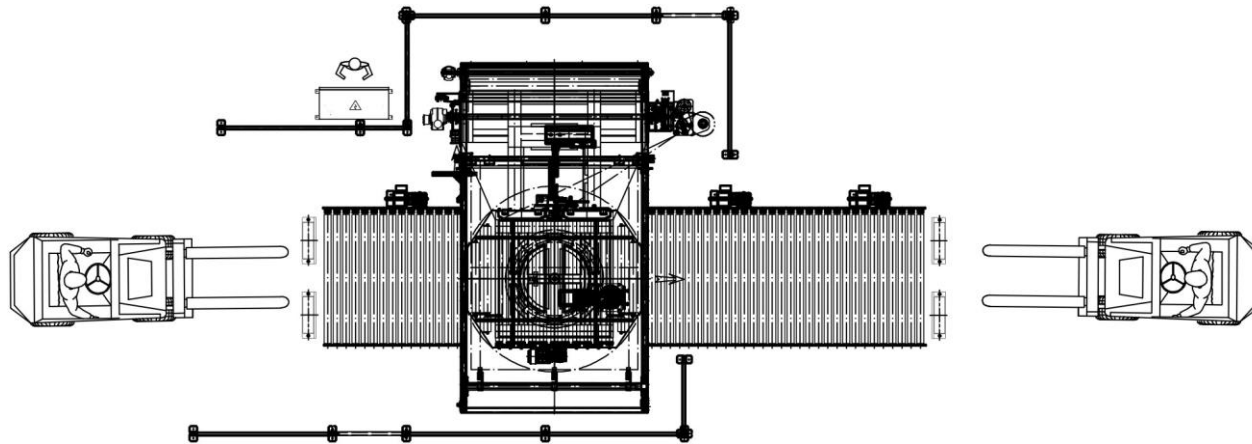

LAYOUT DRAWING

WRAPPING MACHINE IS A KIND OF WRAPPING MACHINE WHICH INTEGRATES THE LAMINATING MACHINE AND THE AUTOMATIC WRAPPING MACHINE TO DESIGN TWO FUNCTIONS OF WRAPPING AND TOP COVER FILM PNEUMATIC DEVICE CLIP FILM, AUTOMATIC FILM BREAKING, AUTOMATIC WELDING FILM, THE WELDING PLACE IS STABLE WITHOUT FILM TAIL MAKE THE FILM STICK TO THE GOODS EFFECTIVELY, PREVENT THE FILM FROM LOOSENING SUITABLE FOR WIDE CARGO WIDTH AND SIZE SLEWING BEARING TRANSMISSION, HIGH PRECISION, STRONG STABILITY, FREQUENCY CONVERSION ADJUSTMENT OF THE TURNTABLE, CONVENIENT MAINTENANCE AND MAINTENANCE, AUTOMATIC RESET TURNTABLE MAN-MACHINE INTERACTION INTERFACE, VARIOUS PARAMETERS CLEAR, ADJUSTABLE RANGE CAN MATCH THE CONVEYOR LINE, DOCKING BEFORE AND AFTER THE ONLINE SIGNAL, TO ACHIEVE AUTOMATIC PACKAGING PLC PROGRAMMABLE CONTROL, WINDING TOP AND BOTTOM PARAMETERS CAN BE SET TIMES PHOTOELECTRIC SYSTEM TO MEASURE THE HEIGHT OF CARGO AUTOMATICALLY



Item	Unit	Parameter
Turntable diameter:	mm	1800
Packing high:	mm	2000
Packaging size:	mm	1200*1200/ L*W
Bearing:		2000Kg
Turntable high:	mm	85
Speed:	Rpm	0~12
Packing efficiency:	Pallet/Hour	30~50
Film pre-stretch	%	150-250
Film tensioning		Adjustable by touch screen
Reel film size	mm	500*260
Weight of film reel	Kg	15
Film thickness	um	17~35
Air	ml/min	1000
Pressure	Mpa	0.4-0.6
Width of the top sheet film	mm	1650
Roller width	mm	1300
Roller diameter	mm	89