

HIGH SPEED ARM TYPE WRAPPING MACHINE

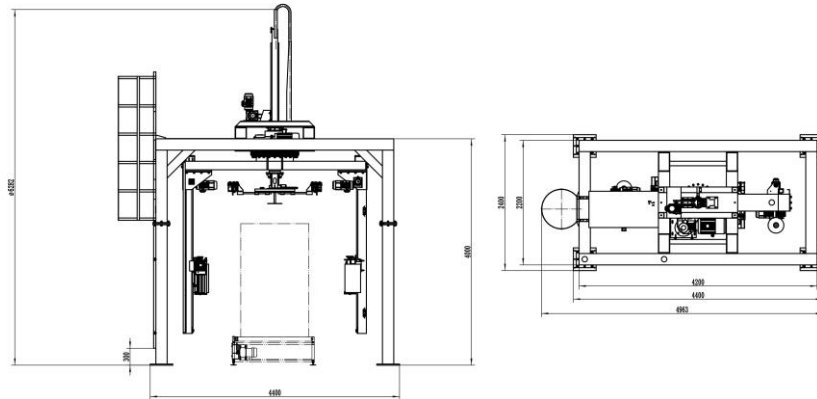

TWO MOTORS SSC ON BOARD, WITH VFD CONTROL DEVICES
VARIABLE PRE-STRETCH 150% - 400% SET VIA CONTROL PANEL
UP TO 12 CONTAINMENT FORCE VALUES ON THE SAME LOAD



LAYOUT SIZE DRAWING (MM)

VARIABLE PRE-STRETCH 150% - 400% SET VIA CONTROL PANEL
UP TO 12 CONTAINMENT FORCE VALUES ON THE SAME LOAD



FULLY AUTOMATED WRAPPING PACKAGING SYSTEM EQUIPMENT

Item	Unit	Parameter
Min-max product dimensions	mm	400x600 - 1220x1220
Standard pallet height	mm	500 - 2000
Standard power supply voltage and frequency	V - Hz	380/400/415 \pm 5% - 50 \pm 1%
Optional power supply voltage and frequency	V - Hz	380-480-600 \pm 5% - 60 \pm 1%
Compressed air pressure	Bar	6 \pm 1
Film tensioning		Adjustable by touch screen
Film pre-stretch	%	125~400
Weight of film reel	Kg	15/20/25
Film thickness	um	17~35