

ARM WRAPPING MACHINE WITH TOP SHEET

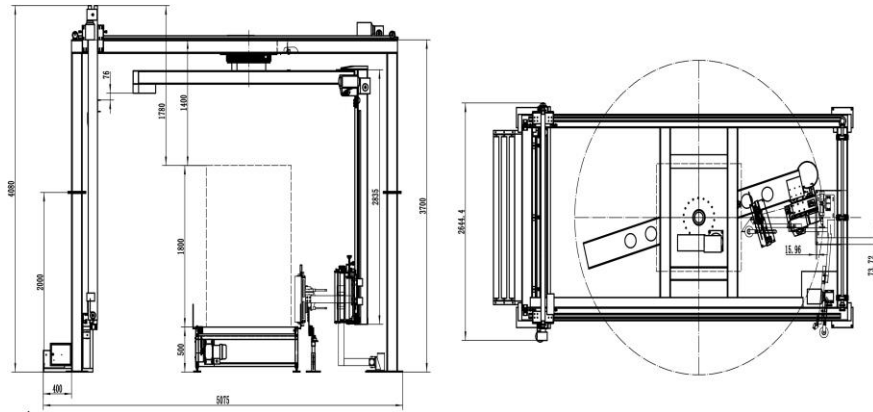

USED FOR WINDING LARGE WEIGHT AND BULK GOODS



LAYOUT SIZE DRAWING (MM)

USED FOR WINDING LARGE WEIGHT AND BULK GOODS
CIRCUMFERENTIAL FIT TOP WRAP WRAP GOODS ON FIVE SIDES

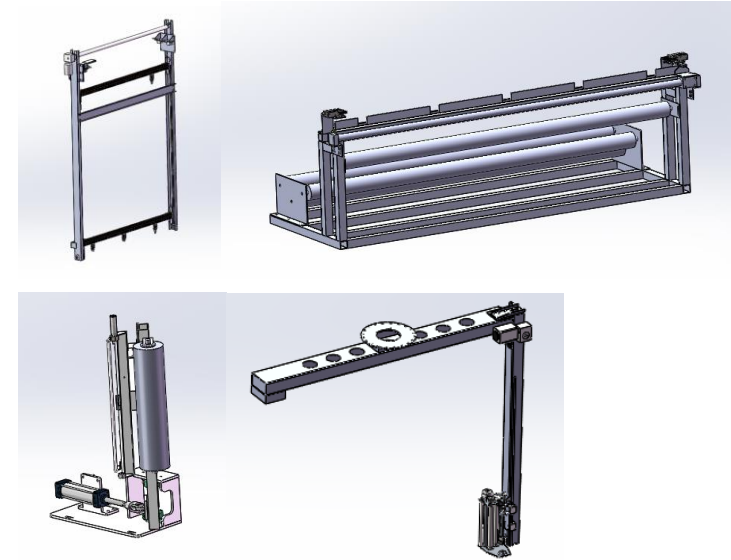

FULLY AUTOMATED WRAPPING PACKAGING SYSTEM EQUIPMENT

Item	Unit	Parameter
Min-max product dimensions	mm	400x600 - 1220x1220
Standard pallet height	mm	500 - 2000
Standard power supply voltage and frequency	V - Hz	380/400/415 ± 5% - 50 ± 1%
Optional power supply voltage and frequency	V - Hz	380-480-600 ± 5% - 60 ± 1%
Compressed air pressure	Bar	6 ± 1
Film tensioning		Adjustable by touch screen
Film pre-stretch	%	125~400
Weight of film reel	Kg	15/20/25
Film thickness	um	17~35